



Carrinho Gaveteiro
Modelo: CGL-220

Carrinho Gaveteiro
*Detalhe lado da porta

Carrinho Gaveteiro
*Detalhe do painel
de ferramentas

Carrinho Gaveteiro
*Detalhe das gavetas

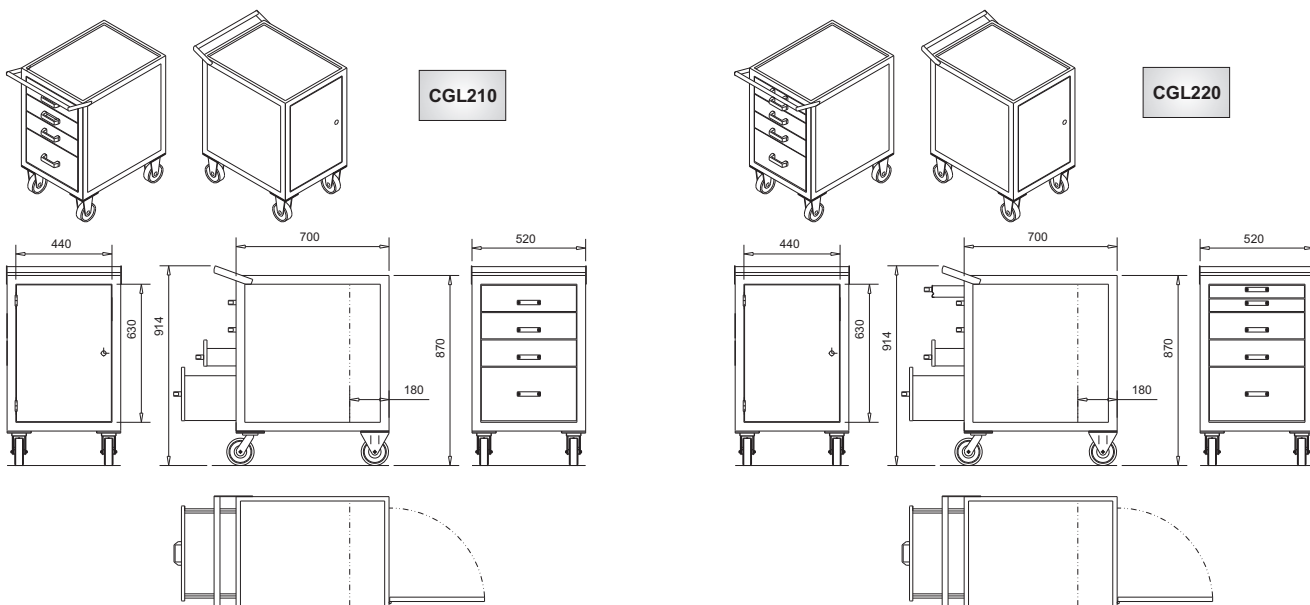

CGL210

CGL220

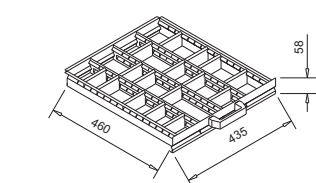

GAVETA PEQUENA
Divisórias Removíveis
Vãos a partir de 90X25mm

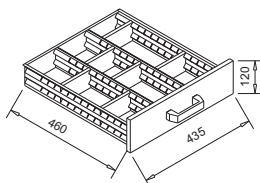

GAVETA MÉDIA
Divisórias Removíveis
Vãos a partir de 130x25mm

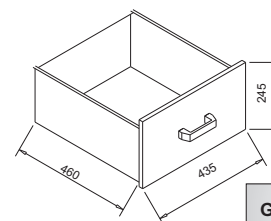

GAVETA GRANDE





Carrinho Gaveteiro Longitudinal
Modelo: CGL-230

Carrinho Gaveteiro Longitudinal

Carrinho Gaveteiro Longitudinal

Carrinho Gaveteiro Longitudinal

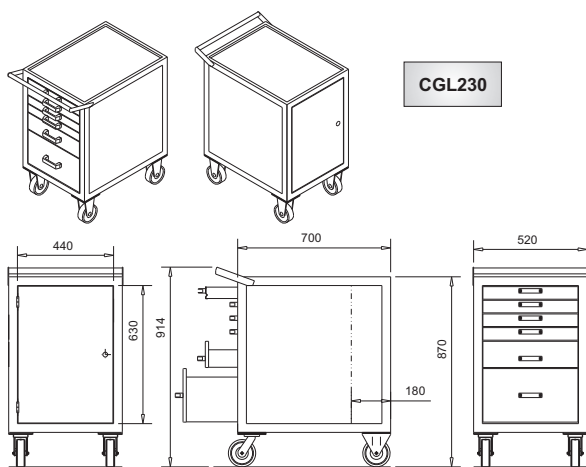

CGL230

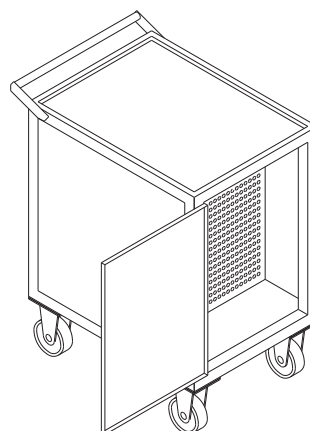

ARMÁRIO DIANTEIRO
Profundidade: 180mm
Fundo com chapa Perfurada

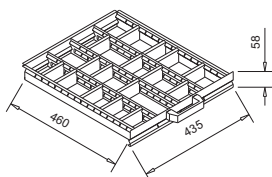
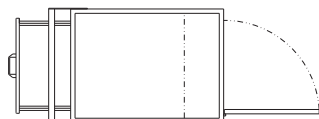

GAVETA PEQUENA
Divisórias Removíveis
Vãos a partir de 90x25mm

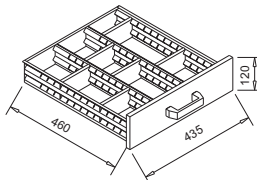

GAVETA MÉDIA
Divisórias Removíveis
Vãos a partir de 130x25mm

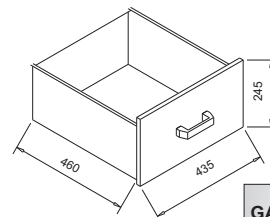

GAVETA GRANDE

